



VISHAY INTERTECHNOLOGY, INC.

TRANSIENT VOLTAGE SUPPRESSORS (TVS)

for Automotive Electronic Protection

DIODES

CAPABILITIES



SEMICONDUCTORS

RECTIFIERS

- Schottky (single, dual)
- Standard, Fast and Ultra-Fast Recovery (single, dual)
- Bridge
- Superrectifier®
- Sinterglass Avalanche Diodes

HIGH-POWER DIODES AND THYRISTORS

- High-Power Fast-Recovery Diodes
- Phase-Control Thyristors
- Fast Thyristors

SMALL-SIGNAL DIODES

- Schottky and Switching (single, dual)
- Tuner/Capacitance (single, dual)
- Bandswitching
- PIN

ZENER AND SUPPRESSOR DIODES

- Zener (single, dual)
- TVS (TRANSORB®, Automotive, ESD, Arrays)

FETs

- Low-Voltage TrenchFET® Power MOSFETs
- High-Voltage TrenchFET® Power MOSFETs
- High-Voltage Planar MOSFETs
- JFETs

OPTOELECTRONICS

- IR Emitters and Detectors, and IR Receiver Modules
- Optocouplers and Solid-State Relays
- Optical Sensors
- LEDs and 7-Segment Displays
- Infrared Data Transceiver Modules
- Custom Products

ICs

- Power ICs
- Analog Switches

MODULES

- Power Modules (contain power diodes, thyristors, MOSFETs, IGBTs)

PASSIVE COMPONENTS

RESISTIVE PRODUCTS

- Film Resistors
 - Metal Film Resistors
 - Thin Film Resistors
 - Thick Film Resistors
 - Metal Oxide Film Resistors
 - Carbon Film Resistors
- Wirewound Resistors
- Power Metal Strip® Resistors
- Chip Fuses
- Variable Resistors
 - Cermet Variable Resistors
 - Wirewound Variable Resistors
 - Conductive Plastic Variable Resistors
- Networks/Arrays
- Non-Linear Resistors
 - NTC Thermistors
 - PTC Thermistors
 - Varistors

MAGNETICS

- Inductors
- Transformers

CAPACITORS

- Tantalum Capacitors
 - Molded Chip Tantalum Capacitors
 - Coated Chip Tantalum Capacitors
 - Solid Through-Hole Tantalum Capacitors
 - Wet Tantalum Capacitors
- Ceramic Capacitors
 - Multilayer Chip Capacitors
 - Disc Capacitors
- Film Capacitors
- Power Capacitors
- Heavy-Current Capacitors
- Aluminum Capacitors

Transient Voltage Suppressors (TVS) for Automotive Electronic Protection

Vishay Intertechnology, Inc.

63 Lancaster Avenue
Malvern, PA 19355
United States
Phone: +1 610 644 1300
Fax: +1 610 296 0657

www.vishay.com

DISCLAIMER All product specifications and data are subject to change without notice. Vishay Intertechnology, Inc., its affiliates, agents, and employees, and all persons acting on its or their behalf (collectively, "Vishay"), disclaim any and all liability for any errors, inaccuracies or incompleteness contained herein or in any other disclosure relating to any product. Vishay disclaims any and all liability arising out of the use or application of any product described herein or of any information provided herein to the maximum extent permitted by law. The product specifications do not expand or otherwise modify Vishay's terms and conditions of purchase, including but not limited to the warranty expressed therein, which apply to these products. No license, express or implied, by estoppel or otherwise, to any intellectual property rights is granted by this document or by any conduct of Vishay. The products shown herein are not designed for use in medical, life-saving, or life-sustaining applications unless otherwise expressly indicated. Customers using or selling Vishay products not expressly indicated for use in such applications do so entirely at their own risk and agree to fully indemnify Vishay for any damages arising or resulting from such use or sale. Please contact authorized Vishay personnel to obtain written terms and conditions regarding products designed for such applications. Product names and markings noted herein may be trademarks of their respective owners.

Important Parameters of TVS	4
• Power Rating	4
• Breakdown Voltage (V_{BR})	4
• Maximum Breakdown Voltage (V_C : Clamping Voltage)	4
• Stand-Off Voltage (V_{WM} : Working Stand-Off Reverse Voltage)	4
Primary Protection of the Automotive Power Line (Dump Load)	5
• What is Load Dump?	5
• Specification and Results of Load Dump Tests	5
• Two Groups of Load Dump TVS	8
Secondary Protection of the Automotive Power Line	9

Important Parameters of TVS

A major challenge in automotive design is protecting electronics – such as control units, sensors, and entertainment systems – against damaging surges, voltage transients, ESD, and noise on the power line. Transient voltage suppressors (TVS) are ideal solutions for automotive electronic protection. In the following section, we discuss the key parameters for TVS devices, including power rating, stand-off voltage, and maximum breakdown voltage.

Power Rating

The power rating of a TVS is its surge-absorbing capability under specific test or application conditions. The industrial-standard test condition of 10/1000 μ s pulse form (Bellcore 1089 spec.) is shown in Figure 1. This test condition differs from the TVS ESD test condition of 8/20 μ s pulse form, as shown in Figure 2.

Figure 1. Test waveform of TVS

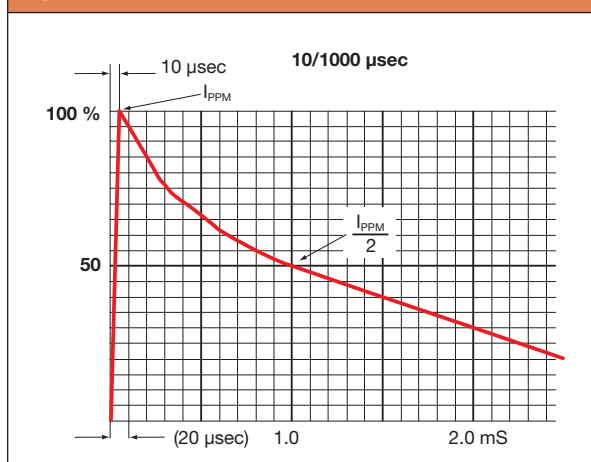
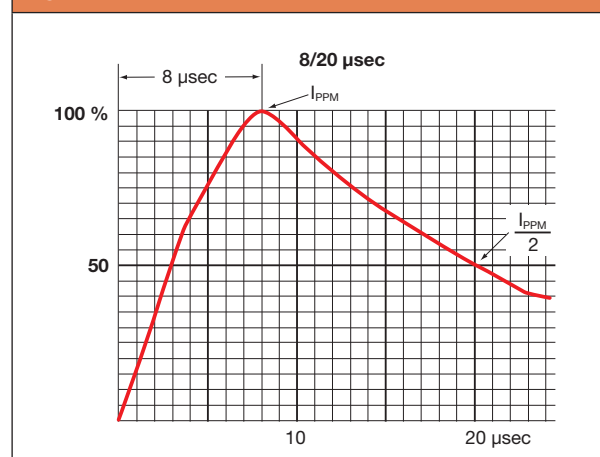

Figure 2. Test waveform of TVS ESD



Breakdown Voltage (V_{BR})

The breakdown voltage is the voltage at which the device goes into avalanche breakdown, and is measured at a specified current on the datasheet.

Maximum Breakdown Voltage (V_C : Clamping Voltage)

The clamping voltage appears across the TVS at the specified peak pulse current rating. The breakdown voltage of a TVS is measured at a very low current, such as 1 mA or 10 mA, which is different from the actual avalanche voltage in application conditions. Thus, semiconductor manufacturers specify the typical or maximum breakdown voltage at a high current level.

Stand-Off Voltage (V_{WM} : Working Stand-Off Reverse Voltage)

The stand-off voltage indicates the maximum voltage of the TVS when not in breakdown, and is an important parameter of protection devices in circuits that do not operate under normal conditions. In automotive applications, some regulation of the automotive electronics is provided by “jump-start protection”. This condition supplies 24 V_{DC} in 10 minutes to 12 V type electronics, and 36 V_{DC} in 10 minutes to 24 V type electronics without damage or malfunction of the circuit. Thus, the stand-off voltage is one of the key parameters in TVS for automotive electronics.

Figure 3. Parameters of voltage and current

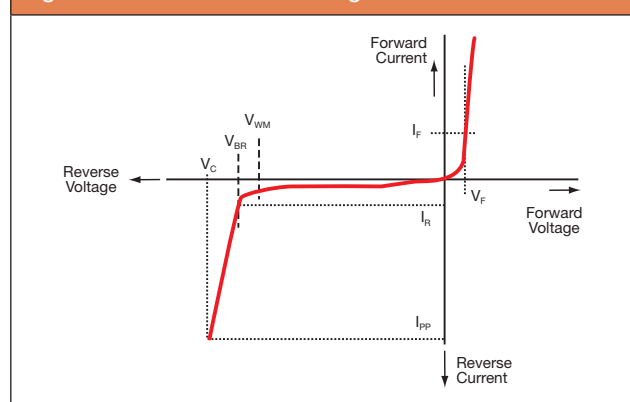

PRIMARY PROTECTION of the Automotive Power Line (Load Dump)



Primary Protection of the Automotive Power Line (Load Dump)

Automotive electronics, such as electronic control units, sensors, and entertainment systems, are connected to one power line. The power sources for these electronics are the battery and alternator, both of which have unstable output voltages that are subject to temperature, operating status, and other conditions. Additionally, ESD, spike noise, and several kinds of transient and surge voltages are introduced into the power and signal line from automotive systems that use solenoid loads, such as fuel injection, valve, motor, electrical, and hydrolytic controllers.

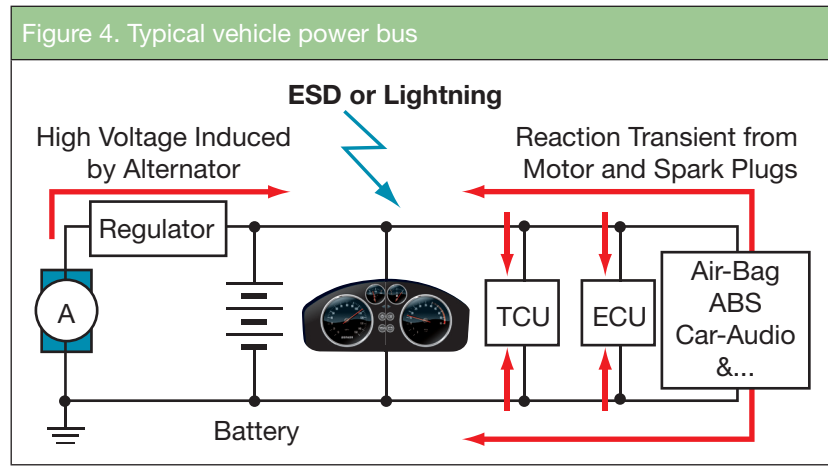

What is Load Dump?

The worst instances of surge voltage are generated when the battery is disconnected when the engine is in operation, and the alternator is supplying current to the power line of the vehicle. This condition is known as “load dump,” and most vehicle manufacturers and industry associations specify a maximum voltage, line impedance, and time duration for this load dump status, as shown in Figure 5.

Two well-known tests simulate this condition: the U.S.’s ISO-7637-2 Pulse 5 and Japan’s JASO A-1 for 14 V powertrains and JASO D-1 for 27 V powertrains. In this section we review the application of TVS for load dump in 14 V powertrains.

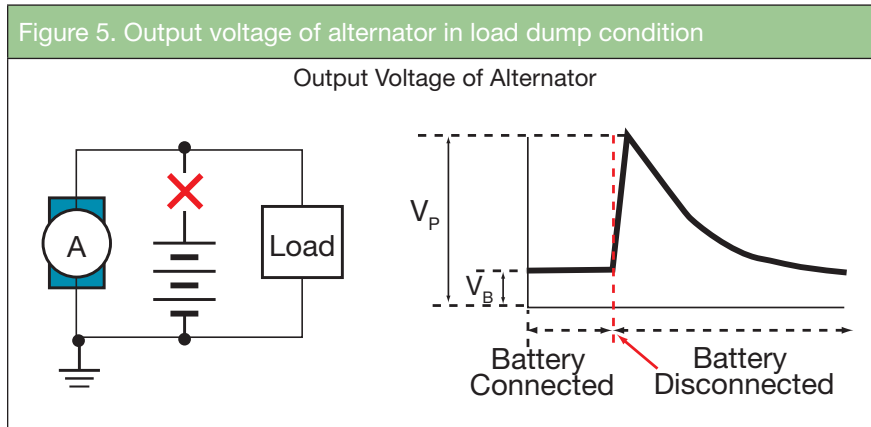

Specification and Results of Load Dump Tests

The U.S.’s ISO-7637-2 Pulse 5 and Japan’s JASO A-1 tests for 14 V powertrains are simulated in Table 1.

Table 1. Major load dump test conditions for 14 V powertrains						
	V Total (V _P) (V)	V _S (V)	V _A (V)	R _i (Ω)	Time (ms)	Cycle Time
JASO A-1	70		12.0	0.8	200	1
	88		12.0	1.0	200	1
ISO 7637-2 Pulse 5	78.5 to 100.5	65 to 87	13.5	0.5 to 4.0	400	1



PRIMARY PROTECTION

of the Automotive Power Line (Load Dump)

Figure 6. For ISO-7637-2 test conditions, the standard condition is a V_S range of 65 V to 87 V, and R_i (line impedance) range of 0.5 Ω to 4 Ω

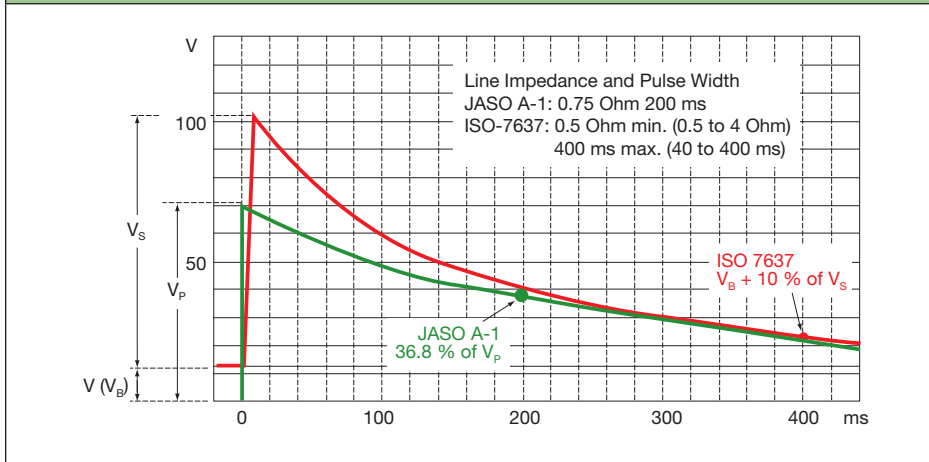

Some vehicle manufacturers apply different conditions for the load dump test based on ISO-7637-2 Pulse 5. The peak clamped current of the load dump TVS will be estimated by the following equation:

Calculation for peak clamping current

$$I_{PP} = (V_{IN} - V_C) / R_i$$

I_{PP} : Peak clamping current

V_{IN} : Input voltage

V_C : Clamping voltage

R_i : Line impedance

Figure 7a shows the current and voltage waveforms of Vishay's SM5S24A in the ISO-7637-2 test of 87 V V_S , 13.5 V V_{batt} , 0.75 Ω R_i and 400 ms pulse width.

Figure 7a: Clamped voltage and current of SM5S24A in ISO 7637-2 test

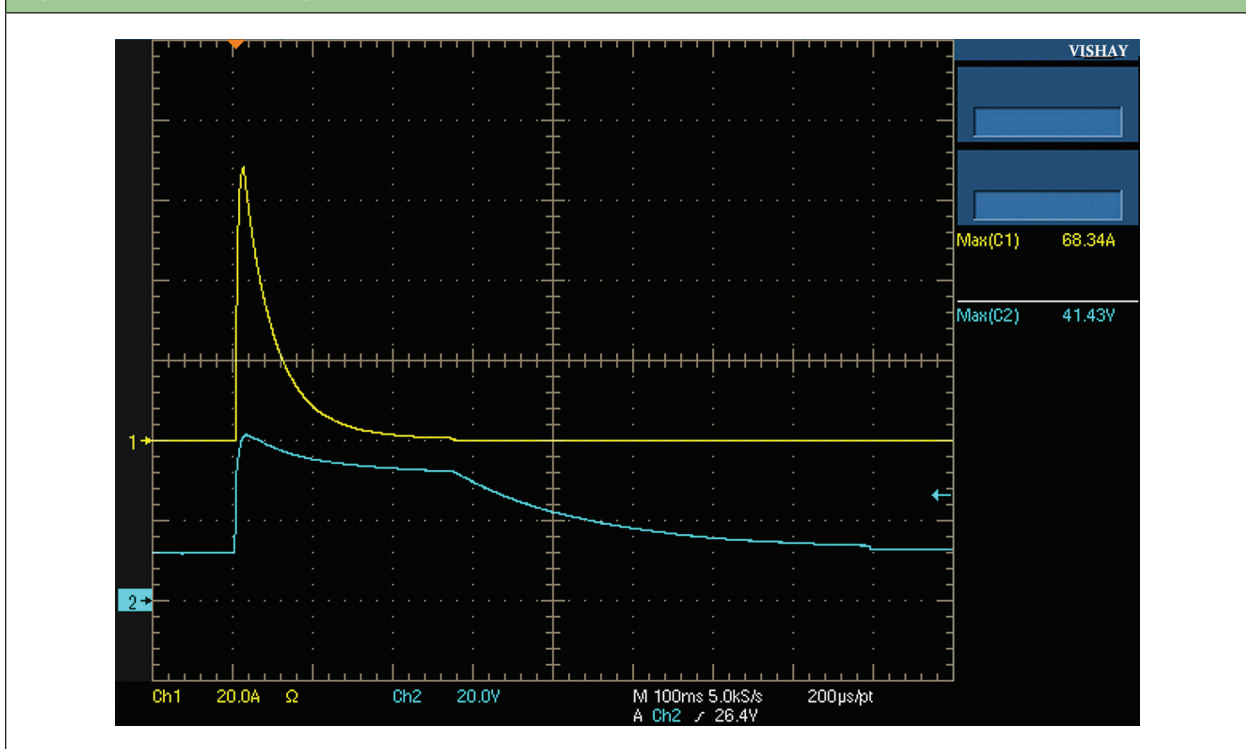

PRIMARY PROTECTION of the Automotive Power Line (Load Dump)



Figure 7b shows the clamped voltage and current of load dump TVS fail in the ISO-7637-2 test of 87 V V_s , 13.5 V V_{batt} , 0.5 Ω R_i and 400 ms pulse width. The clamping voltage drops to near zero, and the current passed through the device is increased to the maximum allowed by the line impedance.

Figure 7b: Clamped voltage and current of load dump TVS failures in ISO7637-2 test

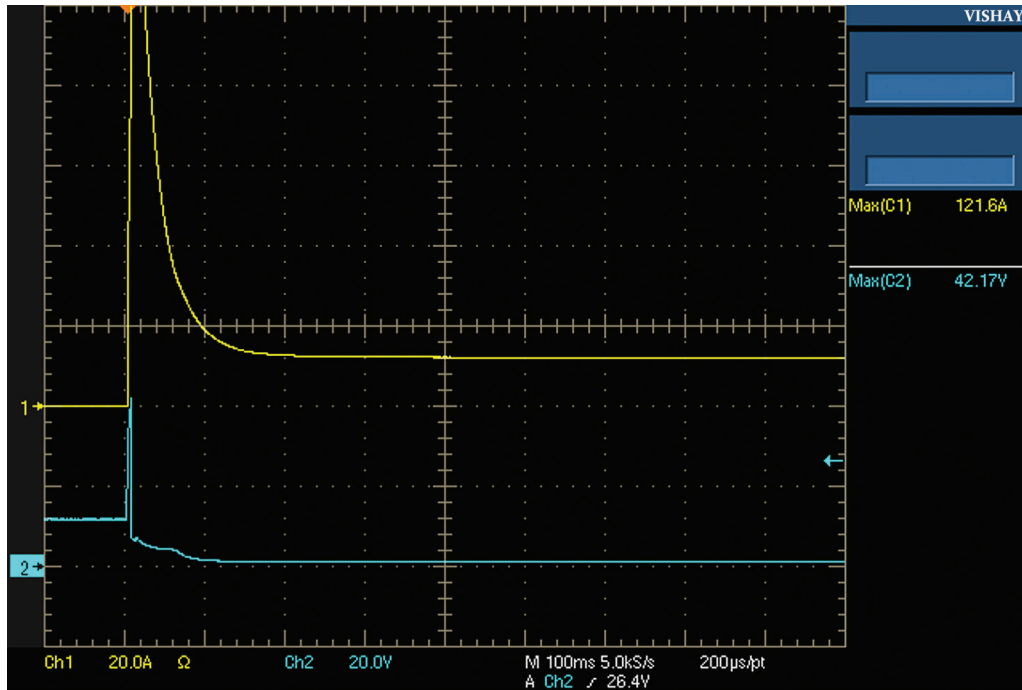

Maximum clamping capability of Vishay load dump TVS of ISO-7637-2 pulse 5 test condition with 13.5V V_{batt} and 400 ms pulse width is as Figure 7c.

Figure 7c: Maximum clamping capability of Vishay load dump TVS in ISO7637-2 test

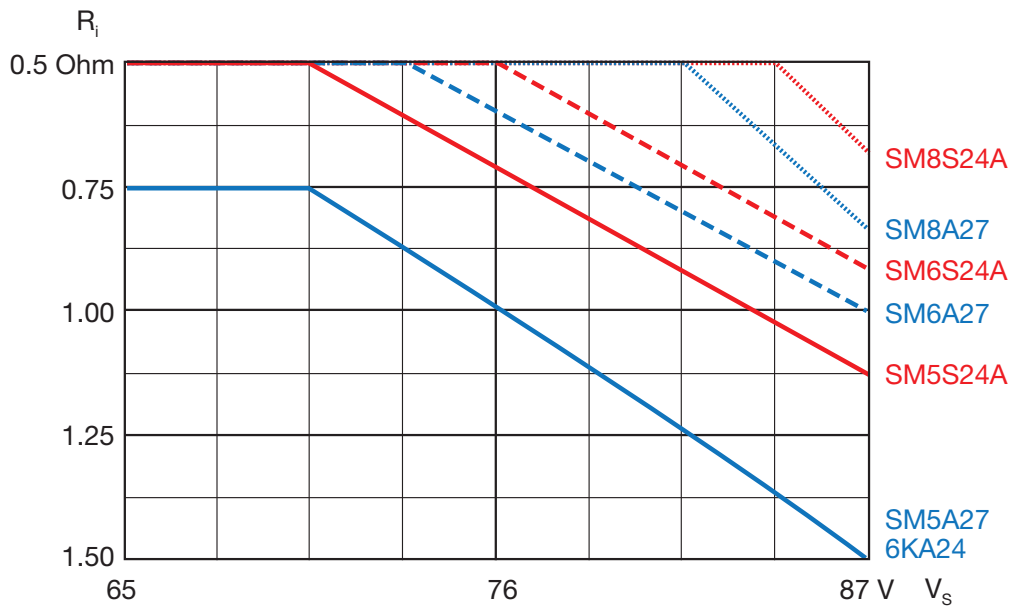



PRIMARY PROTECTION

of the Automotive Power Line (Load Dump)

Two Groups of Load Dump TVS

There are two kinds of load dump TVS for the primary protection of automotive electronics: EPI PAR TVS and non-EPI PAR TVS. Both product groups have similar operating breakdown characteristics in reverse bias mode. The difference is that EPI-PAR TVSs have low forward voltage drop (V_F) characteristics in forward mode, and non-EPI PAR TVSs have relatively high V_F under the same conditions. This characteristic is important to the reverse voltage supplied to the power line. Most CMOS ICs and LSIs have very poor reverse voltage capabilities.

The gates of MOSFETs are also weak in reverse voltage, at - 1 V or lower. In the reversed power input mode, the voltage of the power line is the same as the voltage of the TVS V_F . This reverse bias mode causes electronic circuit failure. The low forward voltage drop of EPI PAR TVSs is a good solution to this problem. Another method to protect circuits from reversed power input is utilizing a polarity protection rectifier into the power line, as shown in Figure 8. A polarity protection rectifier should have sufficient forward current ratings, and forward surge and reverse voltage capabilities.

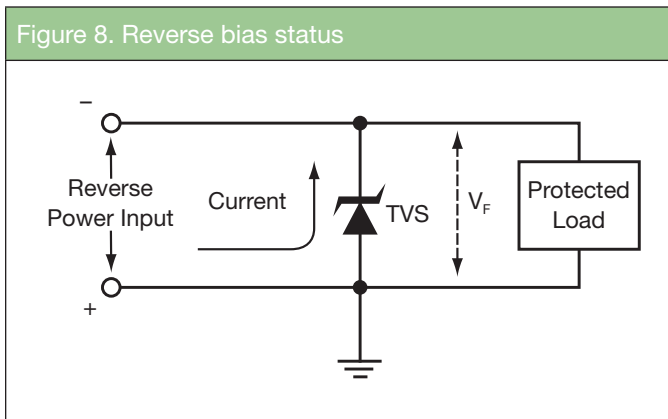

Secondary Protection of the Automotive Power Line

The primary target of protection circuits in automotive systems is high surge voltages, but the clamped voltage is still high. Secondary protection is especially important in 24 V powertrains, such as found in trucks and vans. The main reason for this is the maximum input voltages for most regulators and DC/DC converter ICs for automotive applications are 45 V to 60 V. For this kind of application, using secondary protection, as shown in Figure 9, is recommended.

Figure 9. Secondary protection circuit

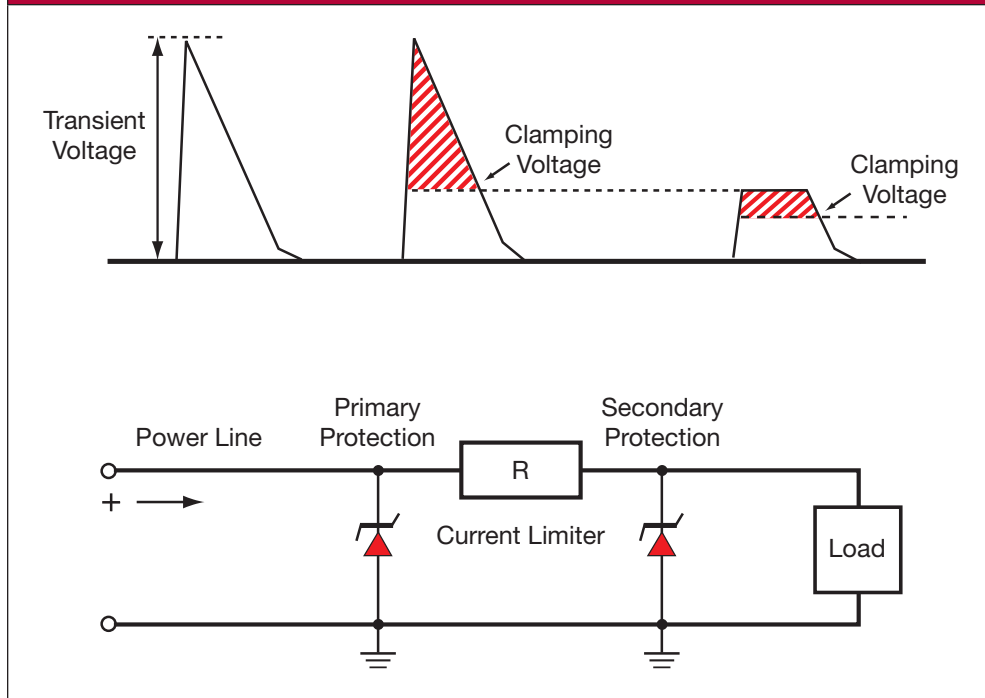

Adding resistor R onto the power line reduces the transient current, allowing smaller power-rating TVSs as the secondary protection. Current requirements for microprocessor and logic circuits in electronic units are 150 mA to 300 mA, and the minimum output voltage of a 12 V battery is 7.2 V at - 18 °C, or 14.4 V for a 24 V battery under the same conditions. In a 24 V battery under the above conditions, the supply voltage at a 300 mA load is 8.4 V at R = 20 Ω, and 11.4 V at R = 10 Ω at a minimum voltage of 14.4 V (24 V battery voltage in - 18 °C).

$$V_L = (V_{min} / (V_{min} / I_L)) \times ((V_{min} / I_L) - R)$$

V_L : Voltage to load

V_{min} : Minimum input voltage

I_L : Load current

R: Resistor value

Power rating of R = I^2R

This supply voltage is higher than the minimum input voltages for most voltage regulators and DC/DC converter ICs.

SEMICONDUCTORS:

Rectifiers • High-Power Diodes and Thyristors • Small-Signal Diodes • Zener and Suppressor Diodes
• FETs • Optoelectronics • ICs • Modules

PASSIVE COMPONENTS:

Resistive Products • Magnetics • Capacitors



One of the World's Largest Manufacturers of
Discrete Semiconductors and Passive Components

WORLDWIDE SALES CONTACTS**THE AMERICAS****UNITED STATES**

VISHAY AMERICAS
ONE GREENWICH PLACE
SHELTON, CT 06484
UNITED STATES
PH: +1-402-563-6866
FAX: +1-402-563-6296

ASIA**SINGAPORE**

VISHAY INTERTECHNOLOGY ASIA PTE LTD.
37A TAMPINES STREET 92 #07-00
SINGAPORE 528886
PH: +65-6788-6668
FAX: +65-6788-0988

P.R. CHINA

VISHAY CHINA CO., LTD.
15D, SUN TONG INFOPORT PLAZA
55 HUAI HAI WEST ROAD
SHANGHAI 200030
P.R. CHINA
PH: +86-21-5258 5000
FAX: +86-21-5258 7979

JAPAN

VISHAY JAPAN CO., LTD.
SHIBUYA PRESTIGE BLDG. 4F
3-12-22, SHIBUYA
SHIBUYA-KU
TOKYO 150-0002
JAPAN
PH: +81-3-5466-7150
FAX: +81-3-5466-7160

EUROPE**GERMANY**

VISHAY ELECTRONIC GMBH
GEHEIMRAT-ROSENTHAL-STR. 100
95100 SELB
GERMANY
PH: +49-9287-71-0
FAX: +49-9287-70435

FRANCE

VISHAY S.A.
199, BLVD DE LA MADELEINE
06003 NICE, CEDEX 1
FRANCE
PH: +33-4-9337-2727
FAX: +33-4-9337-2726

UNITED KINGDOM

VISHAY LTD.
SUITE 6C, TOWER HOUSE
ST. CATHERINE'S COURT
SUNDERLAND ENTERPRISE PARK
SUNDERLAND SR5 3XJ
UNITED KINGDOM
PH: +44-191-516-8584
FAX: +44-191-549-9556

Build **Vishay**
into your **Design**

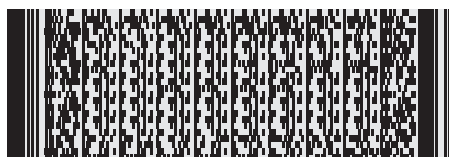

VMN-PL0367-1008

www.vishay.com